

EA740 Series

Inside Containment Areas

Nuclear Qualified Products

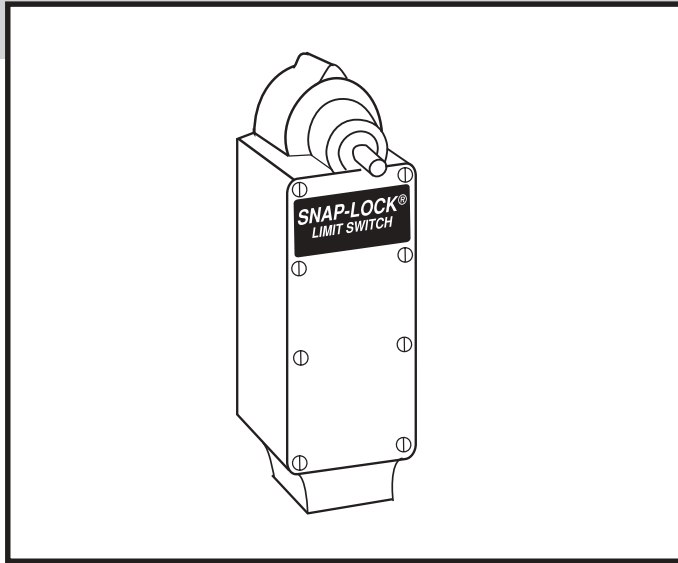

Limit Switches/ Receptacle Assembly... For Nuclear Environments

Features:

- Qualified to IEEE Standards 344-1975, 323-1974, and 382-1972.
- Manufactured to a quality assurance program designed to meet the requirements of 10CFR50, Appendix B, and ANSI N45.2, as applicable.
- Die-cast bronze housing.
- Stainless steel top cover and fasteners.
- Gold-plated contacts.
- High temperature components throughout.
- High temperature lubricants.
- Pressure and radiation resistant
- Seismic and vibration resistant.
- Resists chemical spray.
- Three mounting styles.
- EA 740 has a cam action latching mechanism.

Technical Data:

- Two normally open and two normally closed, NEMA form Z contact arrangement.
- Enclosure meets NEMA 1, 4 and 13 requirements for dust-tight, water-tight and oil-tight applications.
- Operating lever is adjustable in 7°30' increments through 360°.
- Adequate wiring space for nine conductors.
- Rated at 21°C to 90°C.
- Short term exposure to 175°C.
- EA 740 has 18° pre-travel, maximum travel 90°.
- Weight EA 740: 4.3 lbs.; EA 740 with Receptacle: 5.3 lbs.
- DBE maximum test parameters — temperature 340°F, pressure 70 PSIG, radiation 204 megarads gamma.

Continuous Current Rating 75-100% Power Factor*

125 VAC	20 AMPS*
250 VAC	15 AMPS*
480 VAC	10 AMPS*
600 VAC	5 AMPS*
125 VDC	5 AMPS
250 VDC	1.5 AMPS

Receptacle Data

- Qualified receptacle sealed in place.
- Qualified ring tongue terminal applied to leads.
- Every assembly tested before shipment.
- Qualified lead wires.
- Receptacle keyed for proper alignment of connector.
- All circuits wired.
- Circuits of receptacle identified the same as limit switch A, B, C, D, etc.

FOR INSIDE CONTAINMENT AREAS SWITCHES SHOULD BE SPECIFIED AS FOLLOWS:

EA740 Series

Series	Operation	Standard	Wide	Long
		EA740-		
EA740 Standard	CW	20000	50000	80000
	CCW	20001	50001	80001
	CW & CCW (B2 cam)	20100	50100	80100
EA740 Maint.	Maint. "M" Cam	26000	56000	86000
	Maint. "M7" Cam	26700	56700	86700

EA740 Series with Receptacle

Series	Operation	Standard	Wide	Long
		EA740-		
EA740 Standard	CW	20040	50040	80040
	CCW	20041	50041	80041
	CW & CCW (B2 cam)	20140	50140	80140
EA740 Maint.	Maint. "M" Cam	26040	56040	86040
	Maint. "M7" Cam	26740	56740	86740

Male Receptacle Assemblies may be ordered separately.
Please order part number EC290-19001.

Dimensions

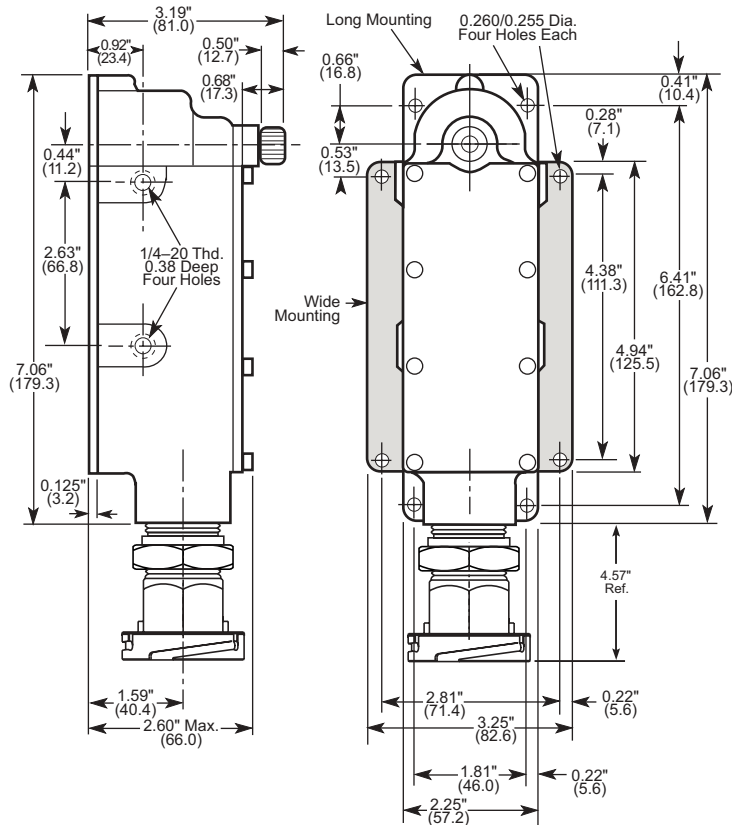

Operational Data

Standard Contacts

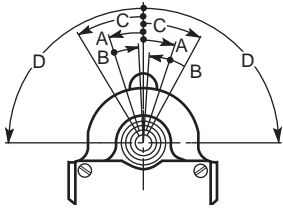

- A. Trip Travel 18°
- B. Reset Travel 14°
- C. Recommended Travel 30°
- D. Total Travel Available 90°
- Torque to Trip (inch Lbs.) 27
- 2 N.O. — 2 N.C.

For CW Switch

CW	Initial	CCW
● ● H ● ● G ● ●	● ●	● ●
● ● F ● ● E ● ●	● ●	● ●
● ● D ● ● C ● ●	● ●	● ●
● ● B ● ● A ● ●	● ●	● ●

For CCW Switch

CW	Initial	CCW
● ● H ● ● G ● ●	● ●	● ●
● ● F ● ● E ● ●	● ●	● ●
● ● D ● ● C ● ●	● ●	● ●
● ● B ● ● A ● ●	● ●	● ●

For CW & CCW Switch

CW	Initial	CCW
● ● H ● ● G ● ●	● ●	● ●
● ● F ● ● E ● ●	● ●	● ●
● ● D ● ● C ● ●	● ●	● ●
● ● B ● ● A ● ●	● ●	● ●

Maintained Contacts & Lever Position

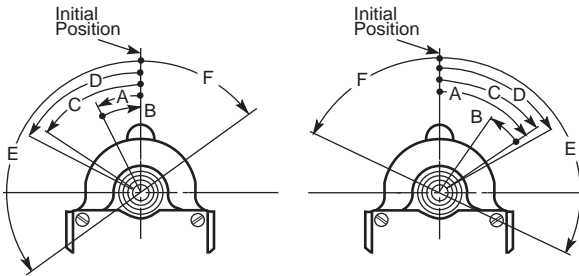

CCW Operating

CW Operating

- | | CCW | CW |
|-------------------------------------|------|------|
| A. Trip Travel | 25° | 55° |
| B. Reset Travel | 25° | 22° |
| C. Min. Travel to Maintain | 54° | 55° |
| D. Recommended Travel | 60° | 60° |
| E. Total Travel | 124° | 116° |
| F. Overall Travel | 56° | 64° |
| G. Torque to Trip (inch Lbs.) | 12 | 6 |

To change switch orientation from cam (left view) position to cam (right view) position, operate switch thru angle C. Remove lever and reset at initial position.

For CW Switch

CW	Initial	CCW
● ● H ● ● G ● ●	● ●	● ●
● ● F ● ● E ● ●	● ●	● ●
● ● D ● ● C ● ●	● ●	● ●
● ● B ● ● A ● ●	● ●	● ●

For CCW Switch

CW	Initial	CCW
● ● H ● ● G ● ●	● ●	● ●
● ● F ● ● E ● ●	● ●	● ●
● ● D ● ● C ● ●	● ●	● ●
● ● B ● ● A ● ●	● ●	● ●

Maintained Contacts — Lever Returned

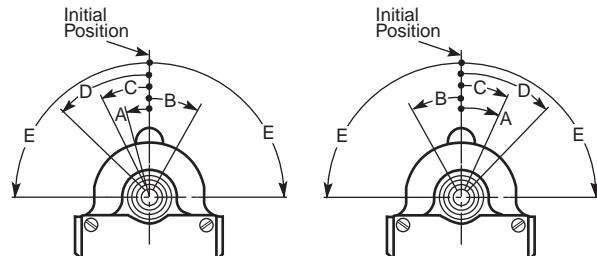

CCW Operating

CW Operating

- | | CCW | CW |
|-------------------------------------|------|-----|
| A. Trip Travel | 16° | 30° |
| B. Reset Travel | 30° | 26° |
| C. Min. Travel to Maintain | 26° | 30° |
| D. Recommended Travel | 45° | 45° |
| E. Total Travel | 90° | 90° |
| F. Torque to Trip (inch Lbs.) | 16.5 | 15 |

To change switch orientation from cam (left view) position to cam (right view) position, operate switch thru angle B. Remove lever and reset at initial position.

For CW Switch

CW	Initial	CCW
● ● H ● ● G ● ●	● ●	● ●
● ● F ● ● E ● ●	● ●	● ●
● ● D ● ● C ● ●	● ●	● ●
● ● B ● ● A ● ●	● ●	● ●

For CCW Switch

CW	Initial	CCW
● ● H ● ● G ● ●	● ●	● ●
● ● F ● ● E ● ●	● ●	● ●
● ● D ● ● C ● ●	● ●	● ●
● ● B ● ● A ● ●	● ●	● ●

Accessories

PLUG-IN CABLES: Cable lengths for the above Switch/ Receptacle Assemblies should be ordered with specific cable lengths as follows . . .

Plug-In Cables	
Length	EC290-
20 Ft.	29020
25 Ft.	29025
30 Ft.	29030
35 Ft.	29035
50 Ft.	29050
100 Ft.	29100

LEVERS: For use inside containment area, levers with bronze arms and beryllium copper rollers are recommended.

Note: Levers must be ordered as separate item. For information request Lever Bulletin EL.

ADAPTORS: Straight and elbow adapters are available for direct mounting into limit switches. See CD/EH700 Series Bulletin.

